



#11127 4' KIDS PICNIC TABLE ASSEMBLY INSTRUCTIONS

TOOLS NEEDED:

Drill with #2 Phillips Bit,
1/4" and 3/32" Drill Bits
2 – 7/16" Wrenches or Sockets
File

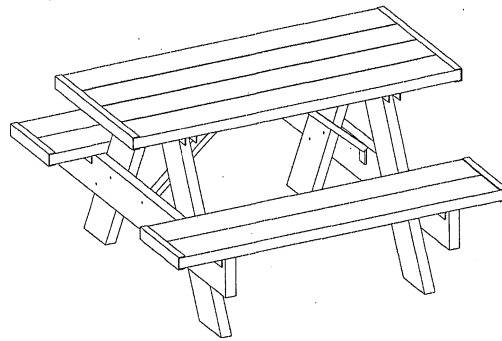

TABLE TOP ASSEMBLY

(Refer to Upper Portion of Drawing 1)

On a large flat non-abrasive surface lay the four 1½ x 5½ x 48" table top rails with pilot holes for screws facing up. (Table top rails have pilot holes farthest from the ends of the rail.) Set the two 20" brackets over the pilot holes on each end of the table top rails, leaving a 1/8" gap between rails. Fasten one bracket to rails with ¾" screws. Repeat for other end of table.

Apply glue to the inside edges of the 7/8 x 1½ x 22¾" end cap and **push** (do not slide from end) the end cap onto the end of each table top, taking care that the end cap is flush with the outer edges of table top.

SEAT ASSEMBLY

(Refer to Lower Portion of Drawing 1) (Make 2)

Lay out 2 pieces of seat rail with pilot holes facing up and an approximate gap of 1/8" between them. (Seat rails have pilot holes closest to the ends of the rail.) Place an 8¾" bracket over pilot holes on one end of the seat rails and fasten bracket to rails with ¾" screws. Repeat on other end of seat.

Apply glue to the inside edges of the 7/8 x 1½ x 11⅛" end caps and **push** onto the ends of the seat rails.



PACKING LIST

#11127 **4' KIDS PICNIC TABLE**

PARTS CONTAINED:

QTY.	PART NO.	PART DESCRIPTION
4	41555-48000	1½ x 5½ x 48" TABLE RAIL
4	41555-48001	1½ x 5½ x 48" SEAT RAIL
2	41555-48002	1½ x 5½ x 48" CROSS RAIL
4	41555-27750	1½ x 5½ x 27¾" LEG
2	4TBCK-20000	20" TABLE BRACKET
4	4TBCK-08750	8¾" SEAT BRACKET
1	47815-21380	7/8 x 1½ x 21¾" CENTER BRACE
2	57815-21250	7/8 x 1½ x 21¼" ANGLE BRACE
2	5ECAP-22380	7/8 x 1½ x 22¾" TABLE END CAP
4	5ECAP-11180	7/8 x 1½ x 11½" SEAT END CAP
4	5ECAP-06180	7/8 x 1½ x 6 1/8" LEG END CAP
4	5ECAP-05500	7/8 x 1½ x 5 ½" CROSS RAIL END CAP
1	7GLUE-40ZCN	4 oz GLUE CAN
		Hardware Bag Includes:
2	7CAPS-7815E	7/8 x 1½" END CAP
64	7HDWR-06034	¾" SCREW
10	7HDWR-06200	2" SCREW
8	7HDWR-14350	¼ x 3½" BOLT
18	7HDWR-14225	¼ x 2¼" BOLT
52	7HDWR-14WSH	¼" FLAT WASHER
26	7HDWR-14NUT	¼" NYLOCK NUT

NOTE: Some parts may be packed inside of others.

If you encounter missing or defective parts, please contact manufacturer direct at toll free # below.

Dura-Trel, Inc. ~ PO Box 122, Sheboygan Falls, WI 53085 ~ Toll Free 877-258-6020

TABLE LEG ASSEMBLY

(Refer to Drawing 2) (Make 2)

Lay two of the 1½ x 5½ x 27¾" leg rails out at an angle, with pilot holes for attaching to table, nearest to each other at top. Lay one of the 1½ x 5½ x 48" cross rails across the legs; adjust legs so bolt holes line up. Using the ¼ x 3½" bolts, washers and nylock nuts, draw bolts up snug (do not over tighten). Note: The bolt heads will face the outside of the table. Using the ⅞ x 1½ x 6 ⅛" angle cut end caps for the bottom of the legs and the ⅞ x 1½ x 5½" end caps for the ends of the cross rail; apply glue and place mentioned above.

COMPLETING TABLE ASSEMBLY

(Refer to Drawing 3)

With tabletop upside down, insert one of the table leg assemblies into the bracket on the underside of the table top, with bolt heads facing the outside of the table. Using the ¼ x 2¼" bolts, washers and nylock nuts, draw bolts up snug with 7/16" wrenches. Repeat for opposite end of table.

DIAGONAL BRACE

Bolt both ⅞ x 1 ½ x 21¼" diagonal braces to the center of the cross rails of table leg assemblies using ¼ x 2¼" bolts, washers and nylock nuts. Bolt heads should face the outside of the picnic table. Fasten the opposite ends of the diagonal braces to the center of the table top as follows; overlap the ends of the two diagonal braces, drill two 3/32" holes through braces and into the tabletop. Fasten with 1½" screws.

SEAT ATTACHMENT

Position seat rail assemblies over the horizontal cross rails of leg assemblies, line up the bolt holes of brackets to the holes in cross rail and fasten with ¼ x 2¼" bolts, washers and nylock nuts.

Upon completion of table be sure to file or sand any sharp edges on the end caps to prevent cuts and scrapes.

Any type of household cleaner without abrasives can be used for cleaning table.

If you encounter missing or defective parts, please contact manufacturer direct at toll free # below.

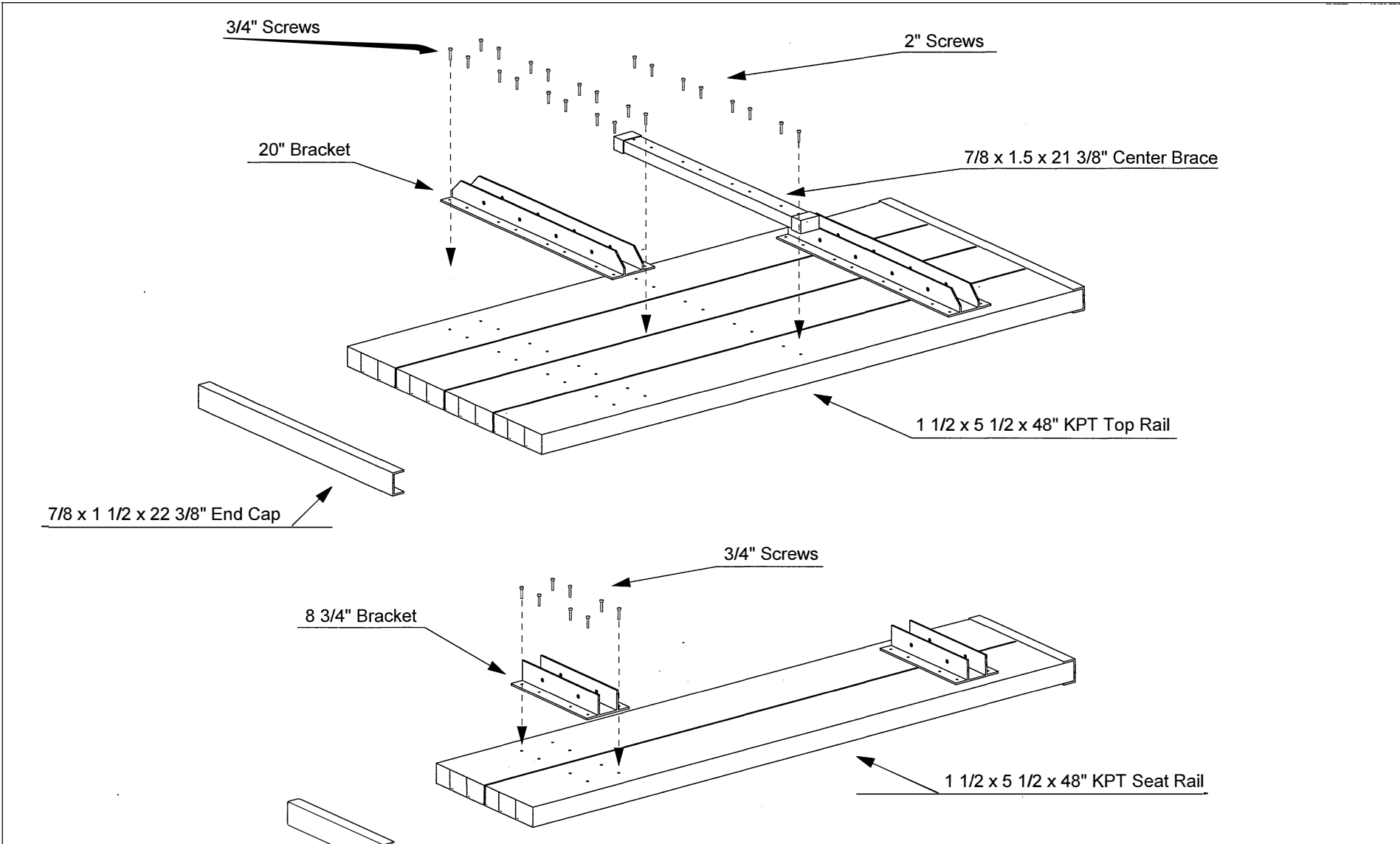

Note: The pilot holes for the seat rails are closer to the ends than the pilot holes for the top rails.

Dura-Trel, Inc.		
P.O. Box 122, Sheboygan Falls, WI 53085		
4' Kids Picnic Table Drawing 1		
Scale: 1'-0" = 1 1/4"	Date: 1-26-05	Drawn By: BLS

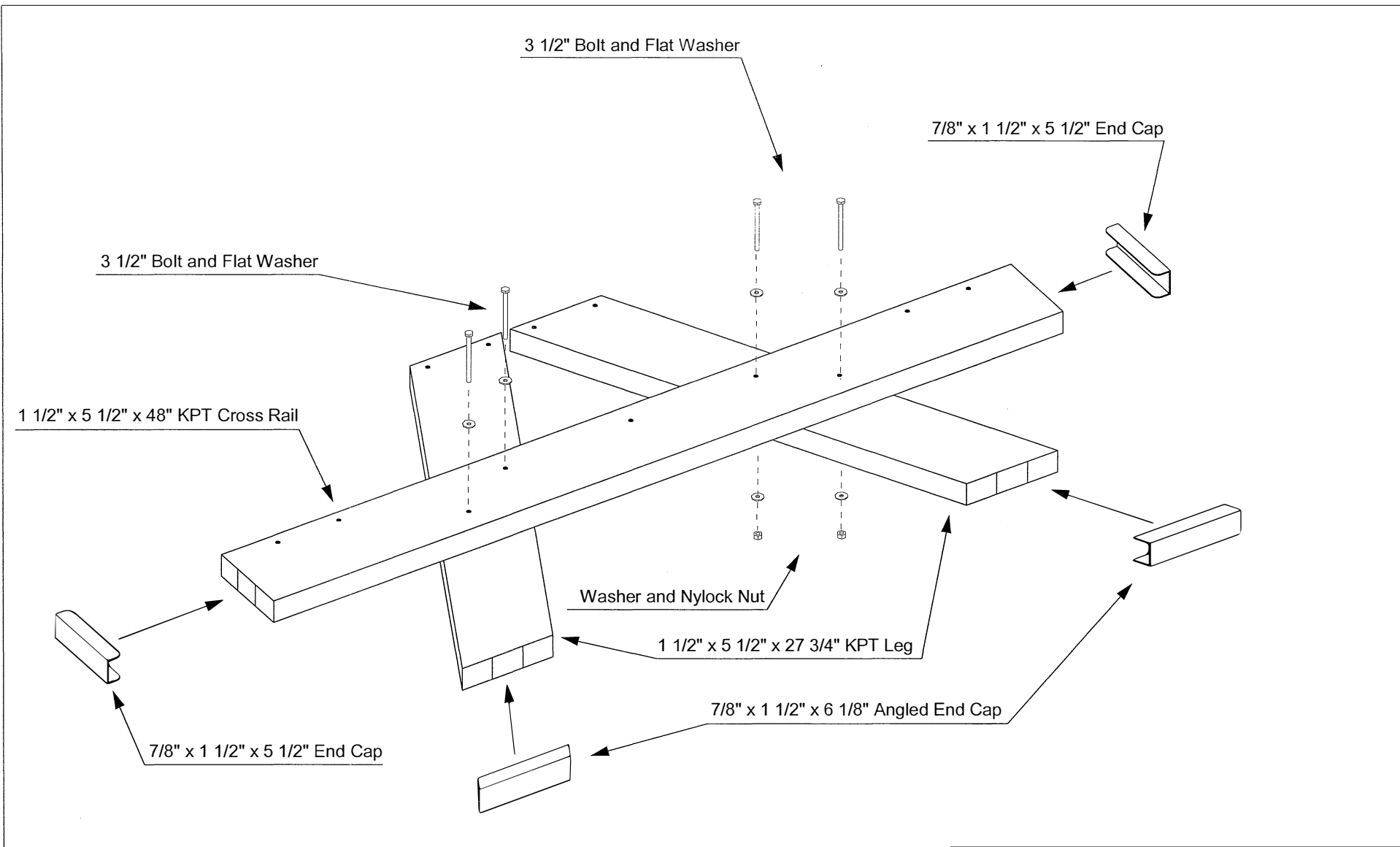

Dura-Trel, Inc.		
P.O. Box 122, Sheboygan Falls, WI 53085		
4' Kids Picnic Table Drawing 2		
Scale: 1'-0" = 1 1/2"	Date: 1-26-05	Drawn By: BLS

2 1/4" Bolts, Washers and Nuts

7/8 x 1 1/2 x 21 1/4" Diagonal Braces
mount in center using 2" screws
with brace ends overlapping
(drill 2 small pilot holes)

2 1/4" Bolts, Washers and Nuts

2 1/4" Bolts, Washers and Nuts

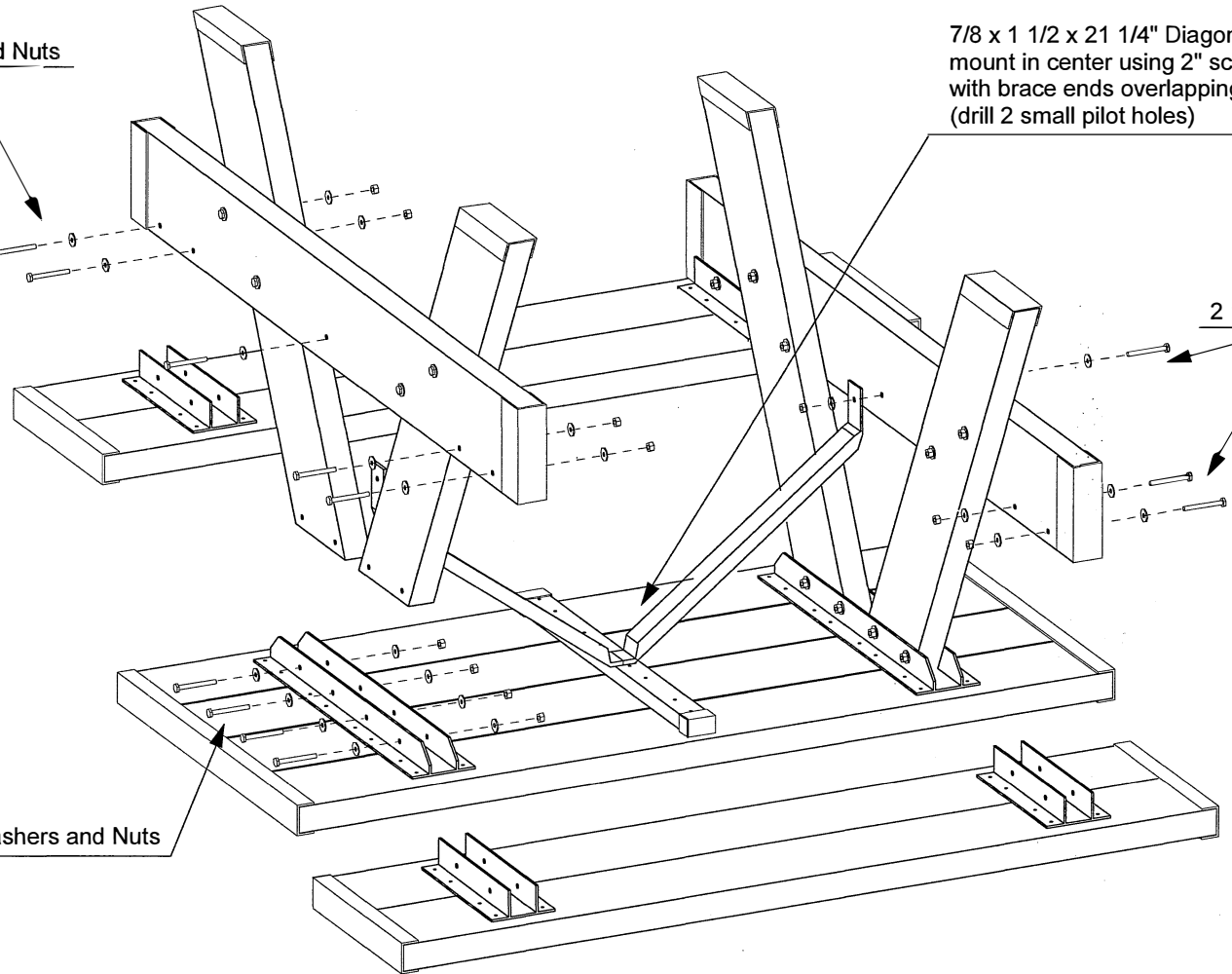

Dura-Trel, Inc.

P.O. Box 122, Sheboygan Falls, WI 53085

4' Kids Picnic Table
Drawing 3

Scale: 1'-0" = 1 1/4"

Date: 1-26-05

Drawn By: BLS



P.O. BOX 122
Sheboygan Falls, WI 53085
Toll Free: 877-258-6020

Please call manufacturer direct with questions concerning missing or defective parts at Toll Free: 877-258-6020.

Dura-Trel, Inc. products are warranted to be free from manufacturing defects resulting in delaminating, peeling, flaking corroding, cracking, crazing, or extreme amounts of fading or bleaching causing the PVC to change to its natural color for a period of 20 years from the date of purchase.

Normal Weathering is defined as exposure to sunlight and extremes of weather and atmosphere which will cause any colored surface to gradually fade.

CONDITIONS NOT COVERED BY THIS WARRANTY:

- A. Physical abuse, misuse, neglect, or improper storage.
- B. Improper installation or installation not in strict adherence to instructions written by Dura-Trel, Inc.
- C. This warranty does not apply if materials are painted, varnished or coated with any substance.
- D. Dura-Trel, Inc. is not responsible for damages to product during shipping.
- E. Damage attributable to atmospheric pollutants, hail, lightning, hurricane, tornado, wind borne objects, earthquake, fire, mildew, casualty, act of God, building or ground settlement, or subjection to stress or weight.

CLAIMS AND REMEDIES:

If a Dura-Trel, Inc. product is determined to have a manufacturing defect which is covered by this warranty, Dura-Trel will replace the material containing the defect (labor not included) F.O.B from the point of manufacture.

Dura-Trel, Inc. will not be responsible for any cost incurred in the removal or reinstallation of the product.

Important: Any claims under this warranty must be made within 30 days after the defect was first discovered or reasonably could have been discovered.

All warranty claims must be sent to the following address and should describe the defect claim.

Dura-Trel, Inc., P.O. Box 122, Sheboygan Falls, WI 53085

Dura-Trel, Inc. reserves the right to discontinue or change its design, and or color. If the original color or style is not available, Dura-Trel, Inc. shall have the right to substitute a product designated by Dura-Trel, Inc.

Dura-Trel, Inc. shall not be liable for any incidental, special, or consequential damages arising out of the use of these products.

20 Y R W a r r a n t y
