

11126 6' PICNIC TABLE W/ UNATTACHED BENCHES ASSEMBLY INSTRUCTIONS

TOOLS NEEDED:

Drill with #2 Phillips Bit,
1/4" and 3/32" Drill Bits
2 - 7/16" Wrenches or Sockets
File

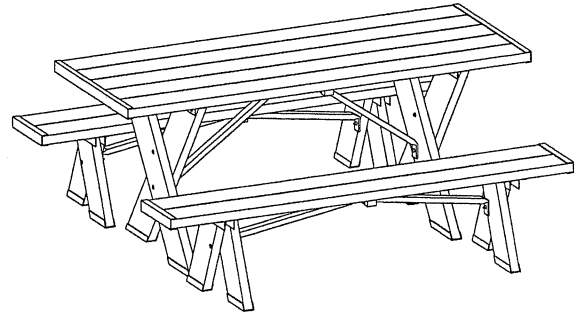

TABLE ASSEMBLY

TABLETOP ASSEMBLY

(Refer to Drawing 1)

On a flat, non-abrasive surface lay out the five tabletop rails found in Box 2 as shown. Rails with wood inserts should be the center rail and the 2 outer rails; leave a 1/8" gap between rails. Set the four Brackets over pilot holes, making sure brackets are offset as shown. Fasten brackets to tabletop rails using 3/4" screws. Apply glue to the inside edges of the 7/8 x 1 1/2" molded end caps and push onto the ends of tabletop center brace. Lay the brace over pilot holes in center of tabletop rails and fasten using 2" Screws. Apply glue to the inside edges of the 7/8 x 1 1/2 x 28" end caps and push onto the ends of tabletop assembly, make sure edges are flush. **Do not slide end caps on from ends of tabletop.**

LEG ATTACHMENT AND TABLE FINISHING

(Refer to Drawing 2) (Make 2)

Loosely bolt two legs together, using 3 1/2" bolts, washers and nylock nuts (make sure pilot holes for brackets are at the same end).

Place one set of legs into the bracket slots; line up pilot holes and fasten legs to tabletop using 2 1/4" bolts, washers and nylock nuts as shown. Repeat for opposite side.

Remove bottom nylock nut on one leg and slide bolt through the hole on diagonal brace, replace nut and tighten snugly. Repeat for opposite side. Overlap the two diagonal braces in the center of table, drill two 3/32" pilot holes through the diagonal braces and into center brace. Fasten with 2" screws to the center tabletop brace.

Apply glue to the inside edges of the 7/8 x 1 1/2 x 7 1/4" angled end caps and push onto the bottoms of each table leg.

BENCH ASSEMBLY

SEAT ASSEMBLY

(Refer to Drawing 3) (Make 2)

Lay out two of the bench rails found in Box 1 as shown, leaving a 1/8" gap between rails. Set the two brackets over pilot holes and fasten brackets to bench rails using 3/4" screws. Apply glue to the 7/8 x 1 1/2" molded end caps and push onto ends of center bench brace. Lay the brace over the pilot holes in center of rails and fasten using 2" screws.

LEG ATTACHMENT AND FINISHING

(Refer to Bench Drawing 4)

Set one of the bench legs with pilot holes into bracket as shown, place a second leg on the inside of the bracket and loosely fasten bracket with 4" bolts, washers and nylock nuts. Set the angled bench brace in place on inside of legs, slide two washers in between legs and fasten with 4" bolt, washers and nylock nuts.

Repeat for opposite end of bench.

Join the diagonal bench braces, so they are overlapping in center, drill two 3/32" holes through the diagonal braces and into the center brace. Fasten using 2" screws.

Apply glue to the 7/8 x 1 1/2 x 11 1/8" end caps and push onto both ends of bench.

Tighten all bolts snugly. Apply glue to the eight 7 1/4" angled end caps and push onto the bottom of each leg.

Upon completion of table be sure to file or sand any sharp edges on the end caps to prevent cuts and scrapes.

If you encounter missing or defective parts, please contact manufacturer direct at toll free # below.

PACKING LIST

#11126 6' TABLE W/ BENCHES

PARTS CONTAINED:

QTY.	PART #	PART DESCRIPTION	BOX #
2	41555-72002W	1½ x 5½ x 72" TABLE RAIL (w/ wood inserts)	1
2	41555-72002	1½ x 5½ x 72" TABLE RAIL	1
1	41555-72003W	1½ x 5½ x 72" CENTER TABLE RAIL w/ (wood inserts)	1
8	41555-15750	1½ x 5½ x 15¾" BENCH LEG	1
4	4TBCK-12750	12¾" TABLE BRACKET	1
4	4TBCK-10750	10 ¾" BENCH BRACKET	1
1	47815-27000	7/8 x 1½ x 27" TABLE CROSS BRACE	1
2	47815-10180	7/8 x 1½ x 10 1/8" BENCH CROSS BRACE	1
2	57815-26500	7/8 x 1½ x 26½" TABLE ANGLE BRACE	1
4	57815-24750	7/8 x 1½ x 24¾" BENCH ANGLE BRACE	1
2	5ECAP-28000	7/8 x 1½ x 28" TABLE END CAP	1
4	5ECAP-11180	7/8 x 1½ x 11½" BENCH END CAP	1
4	5ECAP-07250	7/8 x 1½ x 7¼" TABLE LEG END CAP	1
8	5ECAP-06000	7/8 x 1½ x 6" BENCH LEG END CAP	1
1	7GLUE-4OZCN	4 oz PVC GLUE CAN	1
		Hardware Bag Includes:	1
6	7CAPS-7815E	7/8 x 1½" END CAP	
72	7HDWR-06034	¾" SCREW	
24	7HDWR-06200	2" SCREW	
8	7HDWR-14225	¼ x 2¼" BOLT	
4	7HDWR-14350	¼ x 3½" BOLT	
12	7HDWR-14400	¼ x 4" BOLT	
52	7HDWR-14WSH	¼" WASHER	
24	7HDWR-14NUT	¼" NYLOCK NUT	
		6' TABLE W/ BENCHES INSTRUCTIONS	
4	41555-72004W	W 1½ x 5½ x 72" BENCH RAIL (w/ wood inserts)	2
4	41555-34000	W 1½ x 5½ x 34" TABLE LEG	2

NOTE: Some parts may be packed inside of others.

If you encounter missing or defective parts, please contact manufacturer direct at toll free # below.

Dura-Trel, Inc. ~ PO Box 122, Sheboygan Falls, WI 53085 ~ Toll Free 877-258-6020

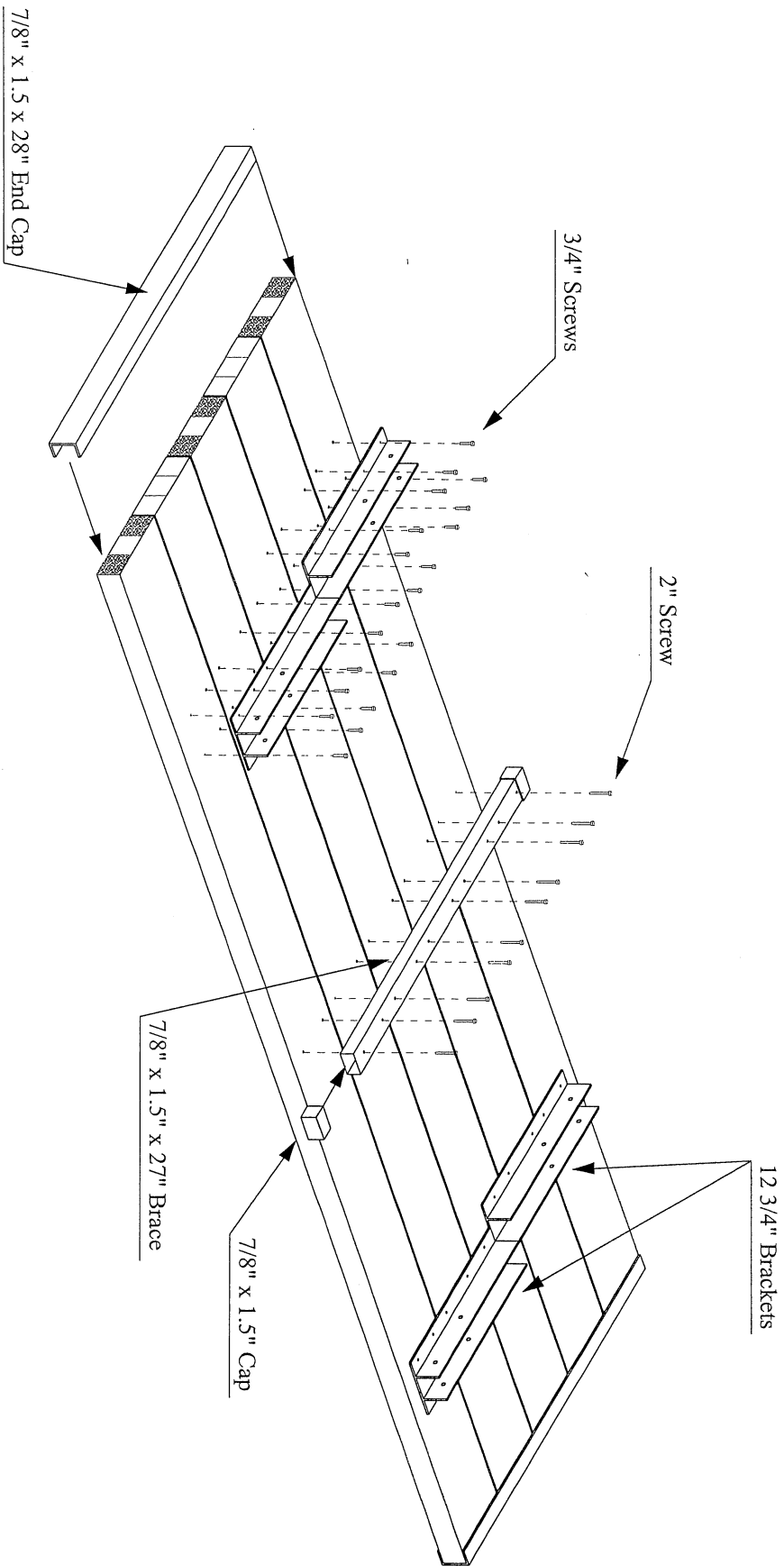

Dura-Trel, Inc.

P.O. Box 122, Sheboygan Falls, WI 53085

6' Table with Benches
Drawing 1

Scale: 1'-0" = 1"

Date: 8-27-99

Drawn By: RJS III

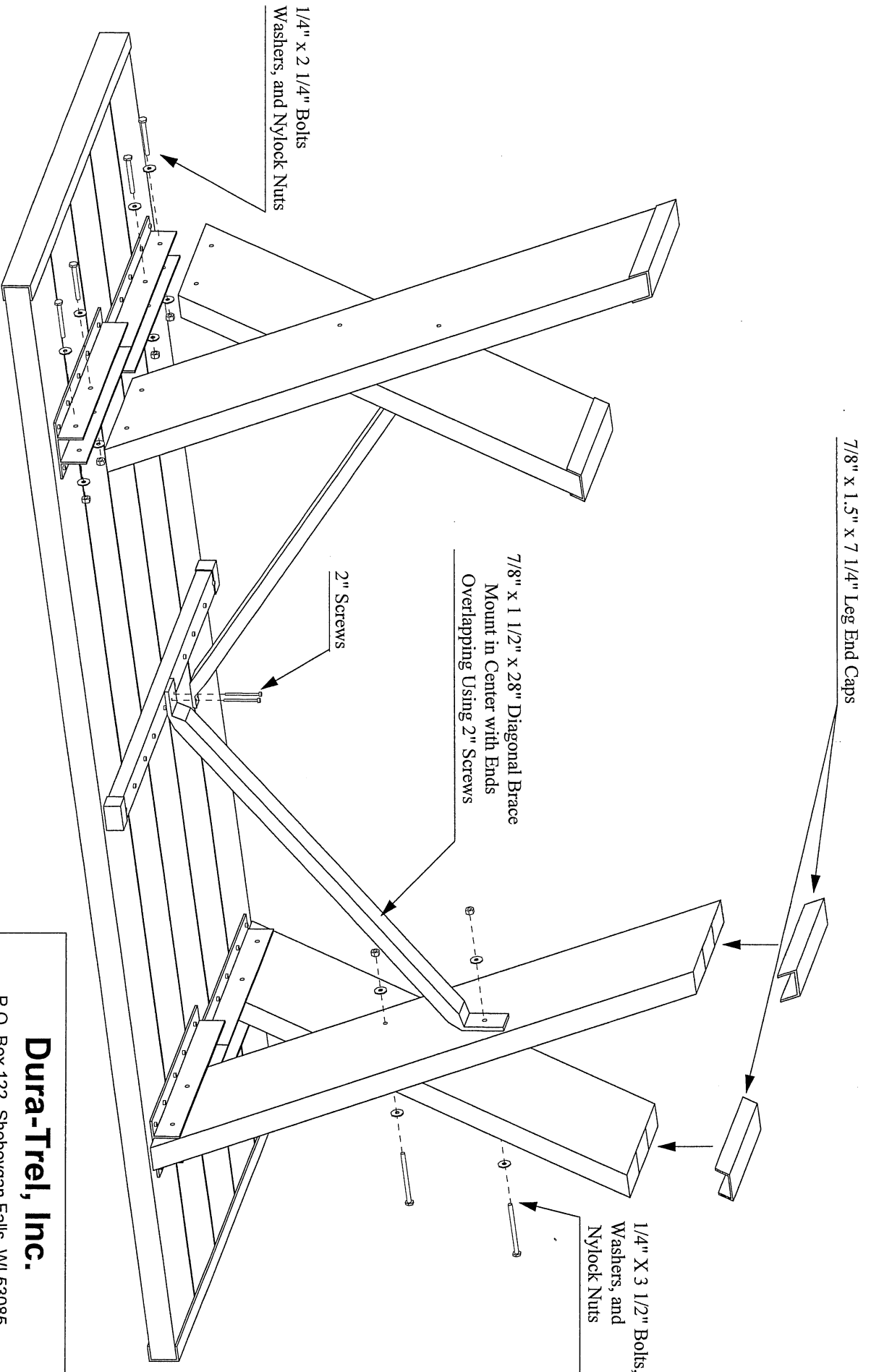

Dura-Trel, Inc.
 P.O. Box 122, Sheboygan Falls, WI 53085

**Outdoor Service Table
 Drawing 2**

Scale: 1'-0" = 1 1/2" Date: 8-27-99 Drawn by: RJS III

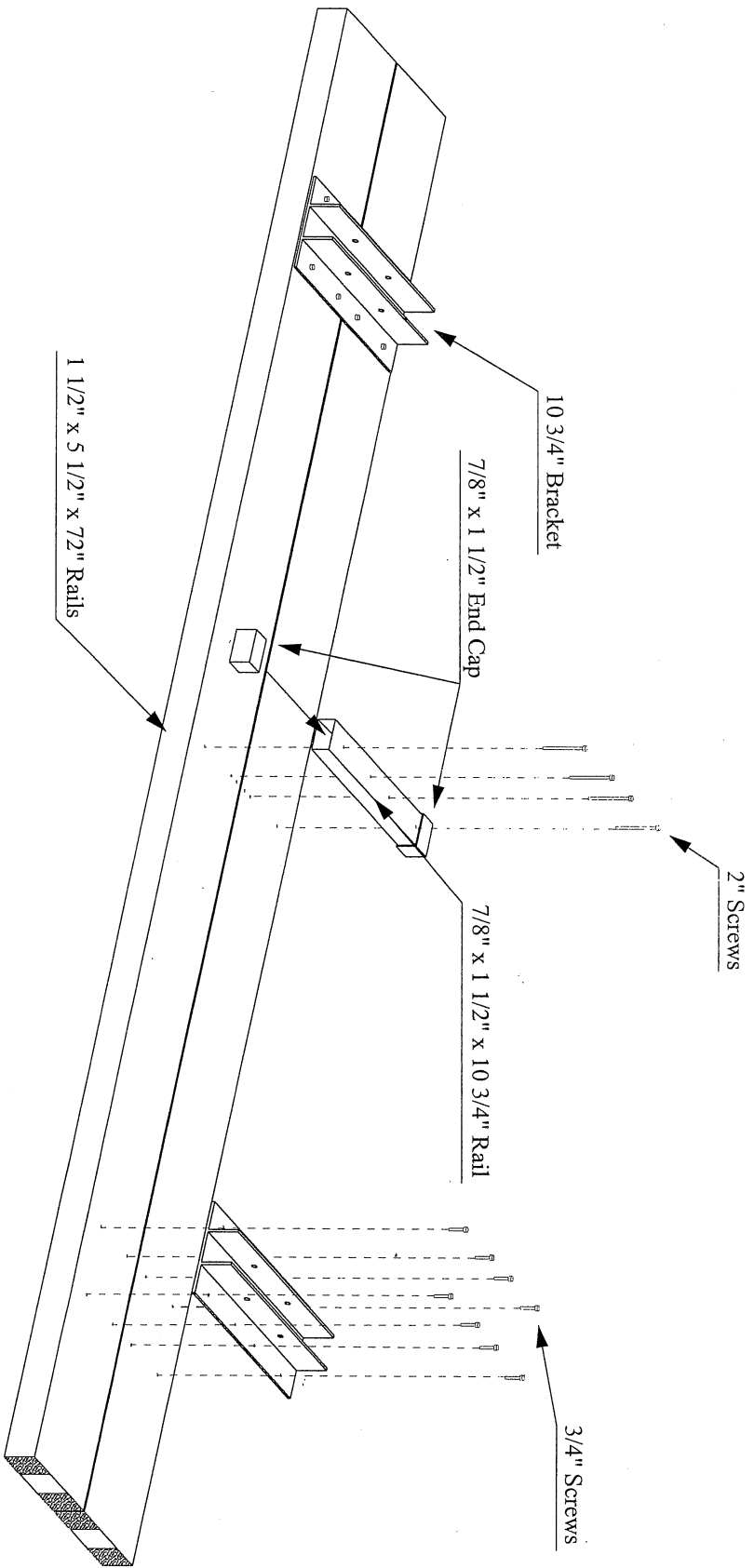

Dura-Trel, Inc.

P.O. Box 122, Sheboygan Falls, WI 53085

6' Table with Benches
Drawing 3

Scale: 1'-0" = 1 1/2"

Date: 4-21-02

Drawn by: RJS III

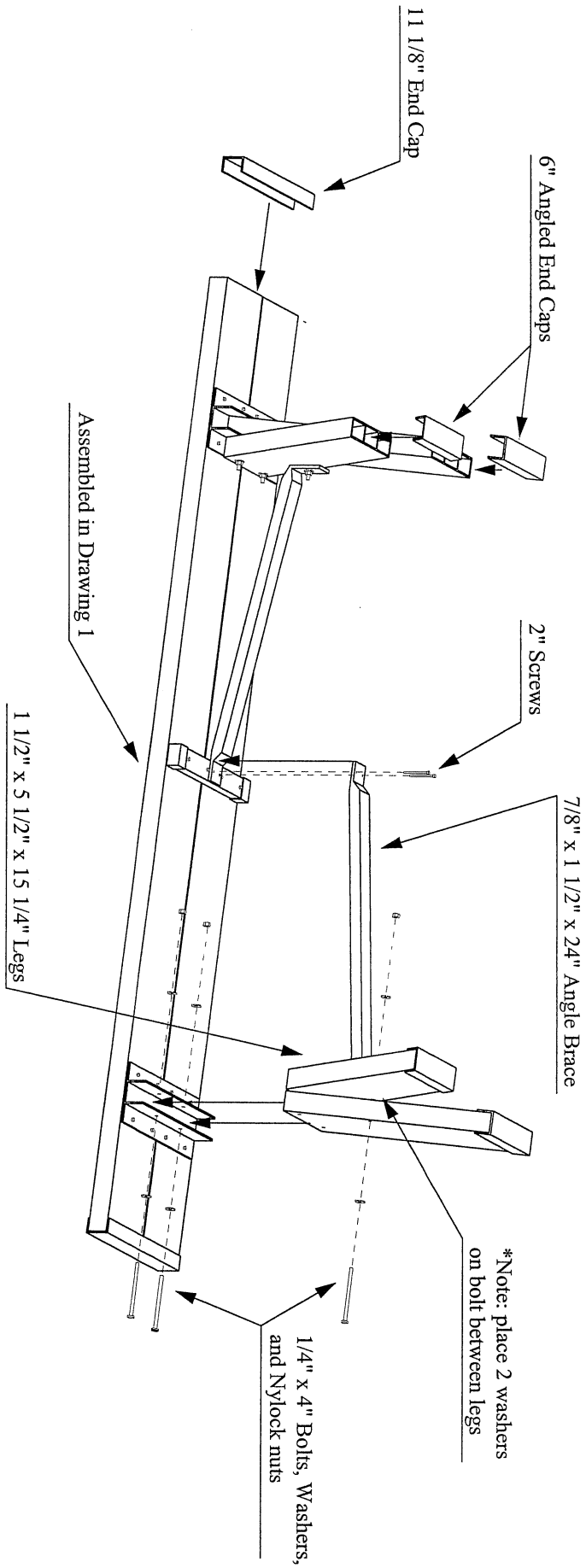

Dura-Trel, Inc.

P. O. Box 122, Sheboygan Falls, WI 53085

**6' Table with Benches
Drawing 4**

Scale: 1'-0" = 1"

Date: 4-21-02

Drawn By: RJS III

DURA-TREL, INC.

P.O. BOX 122
Sheboygan Falls, WI 53085
Toll Free: 877-258-6020

VINYL LAWN & GARDEN PRODUCTS

Please call manufacturer direct with questions concerning missing or defective parts at Toll Free: 877-258-6020.

Dura-Trel, Inc. products are warranted to be free from manufacturing defects resulting in delaminating, peeling, flaking corroding, cracking, crazing, or extreme amounts of fading or bleaching causing the PVC to change to its natural color for a period of 20 years from the date of purchase.

Normal Weathering is defined as exposure to sunlight and extremes of weather and atmosphere which will cause any colored surface to gradually fade.

CONDITIONS NOT COVERED BY THIS WARRANTY:

- A. Physical abuse, misuse, neglect, or improper storage.
- B. Improper installation or installation not in strict adherence to instructions written by Dura-Trel, Inc.
- C. This warranty does not apply if materials are painted, varnished or coated with any substance.
- D. Dura-Trel, Inc. is not responsible for damages to product during shipping.
- E. Damage attributable to atmospheric pollutants, hail, lightning, hurricane, tornado, wind borne objects, earthquake, fire, mildew, casualty, act of God, building or ground settlement, or subjection to stress or weight.

CLAIMS AND REMEDIES:

If a Dura-Trel, Inc. product is determined to have a manufacturing defect which is covered by this warranty, Dura-Trel will replace the material containing the defect (labor not included) F.O.B from the point of manufacture.

Dura-Trel, Inc. will not be responsible for any cost incurred in the removal or reinstallation of the product.

Important: Any claims under this warranty must be made within 30 days after the defect was first discovered or reasonably could have been discovered.

All warranty claims must be sent to the following address and should describe the defect claim.

Dura-Trel, Inc., P.O. Box 122, Sheboygan Falls, WI 53085

Dura-Trel, Inc. reserves the right to discontinue or change its design, and or color. If the original color or style is not available, Dura-Trel, Inc. shall have the right to substitute a product designated by Dura-Trel, Inc.

Dura-Trel, Inc. shall not be liable for any incidental, special, or consequential damages arising out of the use of these products.

20 Y R W a r r a n t y
